

SLOB 72.5 - 550 kV Vertical Break disconnect



We know how

Our range of vertical break disconnectors is designed to ensure the highest performance, with reliability resulting from our 50-year experience.

Over 50000 disconnecting switches installed in more than 100 countries worldwide give the guarantee of a best-buy.

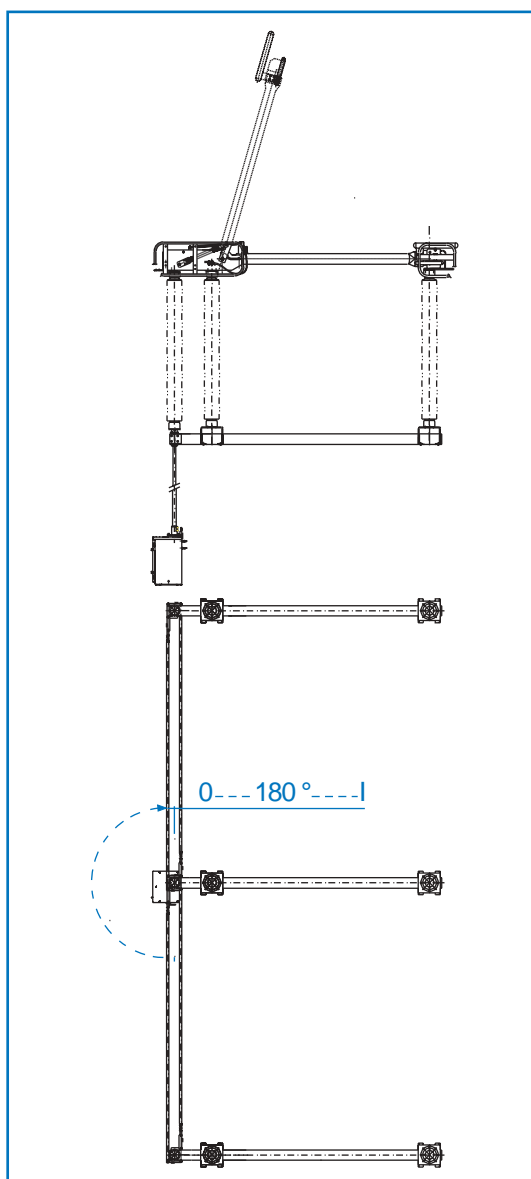

The SLOB vertical break disconnecting switch

The SLOB vertical break disconnecter is formed by three poles, operated simultaneously either by a single operating mechanism and mechanical linkages between the poles or by one mechanism for each pole.

Due to the vertical motion of its main blade, the SLOB disconnecter features very short clearance between phases, allowing space saving in bay design. The insulators, directly bolted on the base frame ensure a good withstand to terminal loads and can comply with either IEC or ANSI standard. Special heights and creepage distances are also available on request.

To adapt to various layouts of substations, the poles can be erected traditionally (horizontal) or wall-mounted, and even upside down.

Like all our models, the SLOB meets the latest international standards (IEC, ANSI) but can also be customised according to particular specification.

Earthing switch

Integrated earthing switches are available for mounting at each or both sides of the pole, with the same short-time current withstand capability.

The earthing switch is actuated by the same types of operating mechanisms as the disconnecter, either manually or electrically, single-pole or 3-pole operation. It can be electrically and/or mechanically interlocked with the main blade.

Construction features

The current path is made of welded and drawn aluminium parts, with silver plated copper contacts. Flexible aluminium straps ensure the connection between the upper frame and the rotary arm. All the hardware of the live part is made of stainless steel.

The upper frame consists in welded aluminium plates, supporting the hinges and the balancing spring. Due to the aluminium straps, the current path between the arm and the upper frame is permanent and can not be cut by external factors, like it could be if this path were established only in the closed position.

Both male and female contacts are silver plated (thickness according to rated current) and protected from corona effects by suitable corona shields, according to rated voltage. The male (moving) contact is bolted on a round aluminium tube.

The female (fixed) contact is of the reverse-loop type, to guarantee the best withstand to short-time currents: the higher is the current, the higher the contact pressure is. The static contact pressure is ensured by stainless steel springs. Furthermore, due to its exclusive kinematics, the mobile contact is locked in the fixed contact, preventing any discontinuity due to electrodynamic or other mechanical force.

The base frame and the rotary support are made of hot-dip galvanised steel profiles. The bearings are sealed and greased for a lifetime of maintenance free operation

All our design and manufacturing process is ruled by ISO 9001 certified procedures to guarantee a perfect repetitivity of the performances from the type-testing to the delivery of series.



Operating principle

The base frame supports two insulators and a rotating insulating rod (drive insulator), which allows to transfer the motion to the moving contact

The live part consists in a rotary blade, with the moving contact bolted at its end, and a fixed contact. The fixed contact **1** (female) is bolted on the top of the insulator and receives the moving one **2** (male), which rotates and travels from the open position to the fully closed position, according to the working principle shown in the opposite figure. The power chain goes through the insulating rod **3**, the crank-lever system **4** and finally to the arm **5**. For a smooth and low power-demanding motion, the rotary blade weight is balanced by springs **6**. The corona rings **7** avoid radio-interference by canceling corona effect according to IEC / CISPR and NEMA standards.

The HV terminals **8** are of the IEC flat type. ANSI or custom terminals are also available upon request.

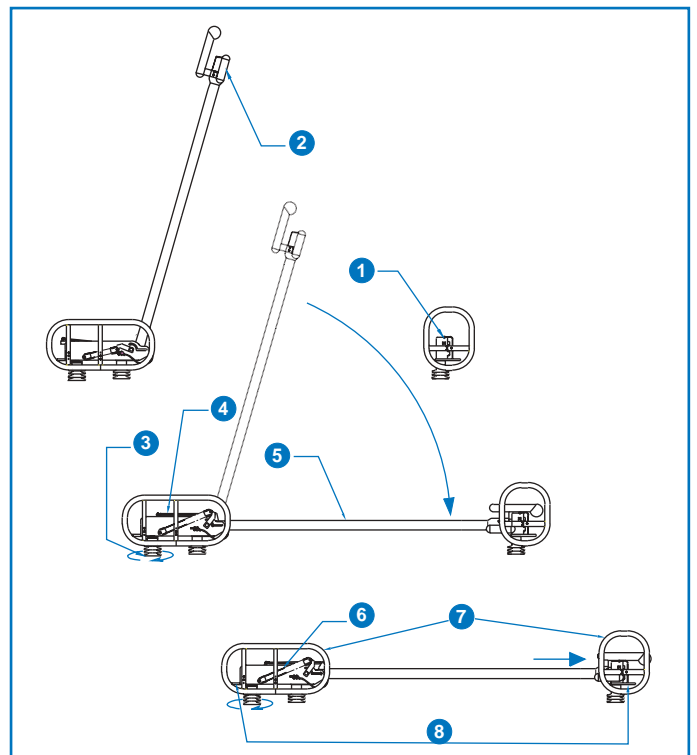

Rated values

Rated voltage		Ur (kV)	72.5	123	145	170	245		300	362	420	550
Rated power frequency withstand voltage	TE	Ud (kV)	140	230	275	325	395	460	380	450	520	620
	AID	Ud (kV)	160	265	315	375	460	530	435	520	610	800
Rated lightning impulse withstand voltage	TE	Up (kV)	325 (IEC) 350 (ANSI)	550	650	750	950 (IEC) 900 (ANSI)	1050	1050	1175	1425	1550
	AID	Up (kV)	375	630	750	860	1050	1200	1050 (+170)	1175 (+205)	1425 (+240)	1550 (+315)
Rated switching impulse withstand voltage	TE	Us (kV)	-	-	-	-	-	-	850	950	1050	1175
	AID	Us (kV)	-	-	-	-	-	-	700 (+245)	800 (+295)	900 (+345)	900 (+450)

TE: To Earth

AID: Across the Isolating Distance

Rated permanent current	Ir (A)	up to 4000 A IEC / ANSI
Rated short-time withstand current	Ik (kA)	up to 75 kA / 3s
Rated peak withstand current	Ip (kA)	up to 190 kA

Dimensions (mm)	A		1100	1600	2100	2100	2900	3200	3200	3700	4200	5000
B	IEC		770	1220	1500	1700	2100	2300	2300	2900	3350	3650
	ANSI		762	1143	1372	1575	2032	2337	2337	3099	-	3861
C	IEC		977	1427	1727	1927	2357	2557	2557	3157	3657	3957
	ANSI		969	1350	1599	1802	2289	2594	2594	3406	-	4168
D			550	550	550	550	550	550	550	550	700	700
E	IEC		3260	3290	4070	4270	5405	5895	5895	6975	8190	9260
	ANSI		2350	3210	3940	4145	5335	5930	5930	7940	-	9470
F			1200	1700	2300	2300	2660	2960	2960	3460	3930	4730
G			-	-	-	-	240	240	240	240	270	270
H			240	240	240	240	270	270	270	270	340	340
J			4 ø 18	4 ø 18	4 ø 18	4 ø 18	8 ø 18	8 ø 18	8 ø 18	8 ø 18	8 ø 22	8 ø 22

Reliability and maintenance

Due to lifetime greased or self-lubricated hinges, and self-wiping contact, the maintenance of the SLOB metallic parts is ensured by its own motion. The use of corrosion-free or protected materials for all the components induces an exceptional reliability over many years of service. The mechanical endurance performance exceeds the IEC standard.

Optional devices

Upon request, the disconnector can be equipped with a bus-transfer current switching device, according to IEC 62271-102 (annex B).

The integrated earthing switch can also be fitted with an optional induced currents switching device, as per IEC 62271-102 (annex C).

For operation under severe ice conditions (up to 20 mm), ice shields are available to protect the parts, where needed.

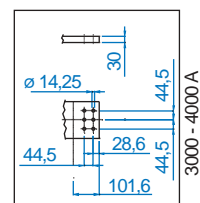
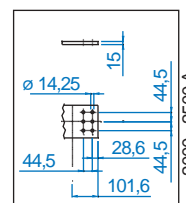
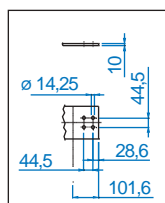
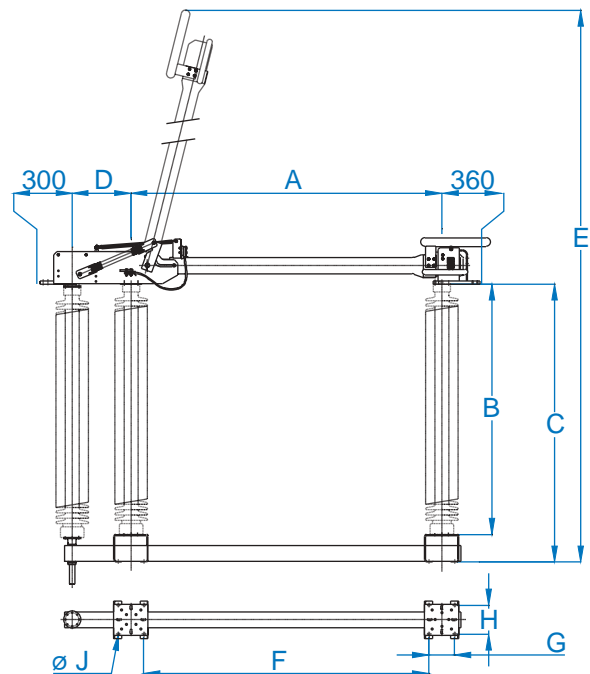

COELME

Via G. Galilei, 1/2 - 30036 Santa Maria di Sala (VE) - Italia
Tel.: +39 041 486022 - Fax: +39 041 486909
E-Mail: contact@coelme-egic.com, www.coelme-egic.com

EGIC

86, chemin de la Mouche - BP 6 - 69563 St-Genis-Laval - France
Tel.: +33 4 72 66 20 70 - Fax: +33 4 72 39 08 65
E-Mail: contact@coelme-egic.com, www.coelme-egic.com