

Installation and Service Instructions

UH 206-101c

3250 006 101 c

Safety information

- ☞ Do not pick up by the electronic unit
- ☞ Be careful of sharp edges (thread, flange, measuring tube)
- ☞ Installation and removal must be performed by qualified personnel only
- ☞ Mounting and unmounting are only permitted when the system is not under pressure
- ☞ After installation, a tightness test must be conducted with cold pressure
- ☞ Only ever use under service conditions, otherwise dangers can arise and the warranty may be voided
- ☞ Breaking the calibration seal voids the warranty
- ☞ The 110 V / 230 V versions must only be connected by an electrician
- ☞ The lithium batteries must be properly returned
- ☞ Lightning protection cannot be ensured; this must be provided by the building wiring
- ☞ Only one compartment for the power supply must be equipped – do not remove the red locking hatch

General information

The electronic unit is plugged onto an adapter plate and can be separated by pushing the volume measuring unit upward.

The packaging should be kept so that the heat meter can be shipped in its original packing after the calibration period has elapsed.

If the heat meter was not supplied with a battery connected, the current date and time must be entered during start-up (see "Parameter setting").

The 110 V / 230 V power supply units comply with safety class II, so the line voltage does not need to be disconnected when changing the unit.

All cables must be laid at a **minimum distance of 300 mm** from power cables or radio-frequency cables.

By overpressure, cavitation must be avoided in the entire measuring range, i.e. **at least 1 bar at q_p** and approx. 3 bar at q_s (applies to approx. 80°C).

The heat meter left the factory in perfect safe condition. Calibration, maintenance, component replacement, and repairs must only be performed by trained personnel who are familiar with the hazards involved. The manufacturer will provide further technical support on request. Heat meter safety marks that are relevant for calibration must not be damaged or removed! Otherwise the warranty and calibration validity of the device will expire.

Installation

Choose the mounting location (return or flow) in accordance with the labeling on the heat meter. Study the table for the dimensions and check that there is enough clearance.

No inlet or outlet sections are necessary. However, if the heat meter is installed in the shared return of two heating systems, e.g. heating and hot water, the mounting location must be a sufficient distance from the T element that forms the junction (**min. 10 × DN**) to allow the different water temperatures to mix well. Before the heat meter is installed, the system must be rinsed thoroughly.

As shown in the examples on Page 2, mount the volume measuring unit horizontally or vertically between two shut-off valves in accordance with the arrow for the direction of flow. The sensors must be mounted in the same heating circuit as the volume measuring unit. For installation as a **cold meter**, see the following notes.

The sensor can be mounted in ball valves, in pockets or direct immersed. The end of the sensors must extend in any case as far as the center of the pipe cross-section. Temperature sensors and screw joints must be sealed for protection from tampering.

Small heat meters (q_p 0.6 - 2.5 m³/h)

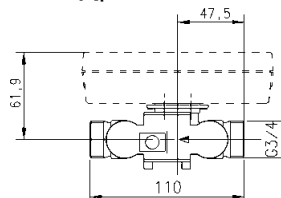

Overall length 110 mm (thread)

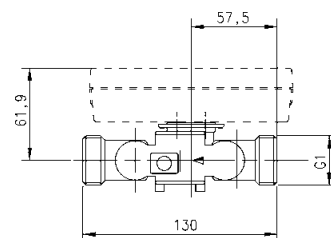

Overall length 130 mm (thread)

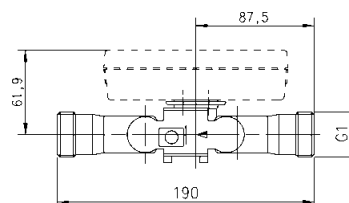

Overall length 190 mm (thread)

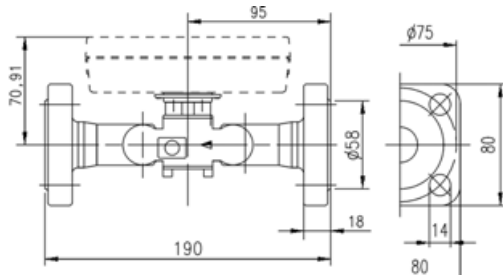

Overall length 190 mm (flange)

Large heat meters with threaded joint

alternative mounting option

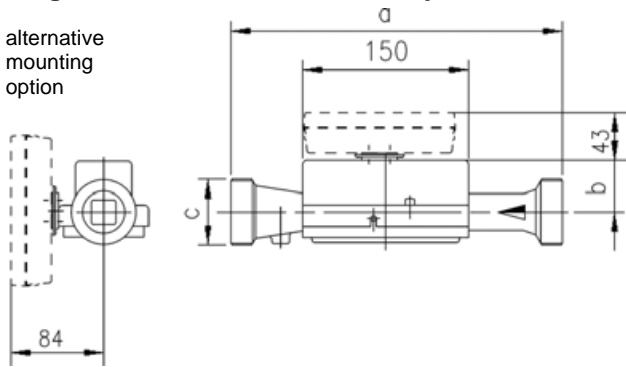

Order no.	qp m ³ /h	PN bar	a	b	c
UH50x 45	3.5	16	260	51	G 1 1/4 B
UH50x 47	3.5	25	260	51	G 1 1/4 B
UH50x 50	6	16	260	51	G 1 1/4 B
UH50x 60	10	16	300	48	G 2 B

Large heat meters with flange joint

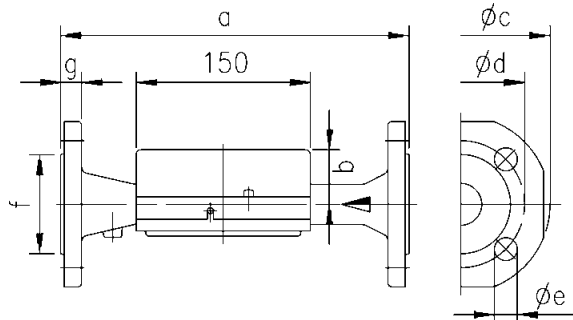

Order no.	qp m ³ /h	PN bar	DN	a	b	Øc	Ød	Øe	No. of holes	f	g
UH50x 46	3.5	25	25	260	51	115	85	14	4	68	18
UH50x 52	6	25	25	260	51	115	85	14	4	68	18
UH50x 61	10	25	40	300	48	150	110	18	4	88	18
UH50x 65	15	25	50	270	46	165	125	18	4	102	20
UH50x 70	25	25	65	300	52	185	145	18	8	122	22
UH50x 74	40	25	80	300	56	200	160	18	8	138	24
UH50x 82	60	16	100	360	68	235	180	18	8	158	24
UH50x 83	60	25	100	360	68	235	190	22	8	158	24

Examples of installation

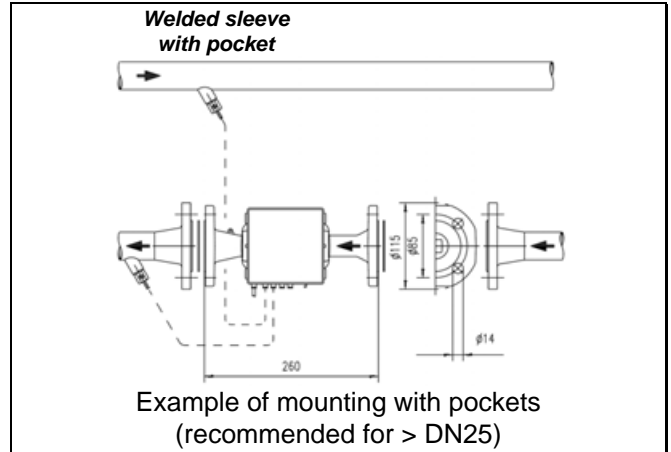
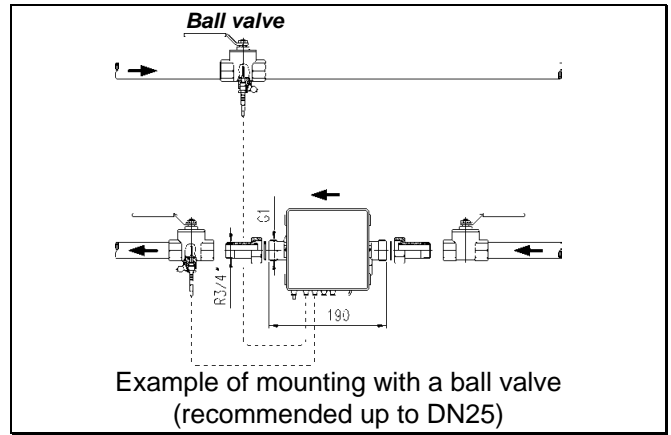

Hint for mounting adapter set (sensor direct immersed)

For heat meters with temperature sensor 5,2x45 mm a mounting set is enclosed. Hereby the sensor can be installed direct immersed e.g. in a mounting element or a ball valve.

Mounting advice (see figure): Install O-ring with enclosed fit-up aid/fit-up pen in the mounting point. Take both halves of the plastic bolting and put them around the 3 gaps of the sensor, compress and screw in until bedstop (hand-screwed, fastening torque 3 – 5 Nm).

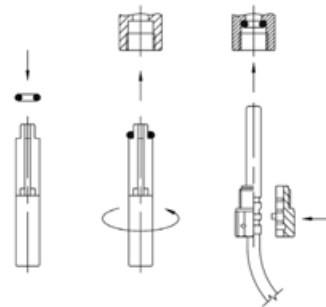

Mounting adapter set

Mounting as a cold meter

When mounting a **cold meter** or **combined heat/cold meter**, make sure the black cover on the measuring tube is oriented to the side and downward (because of water condensation).

The measuring tube must **always be mounted in the return**. The electronic unit must be separated from the flowrate measuring tube and, for example, mounted on the wall (split mounting). Make sure that condensed water cannot run along the connected pipes into the electronic unit (building a loop downwards).

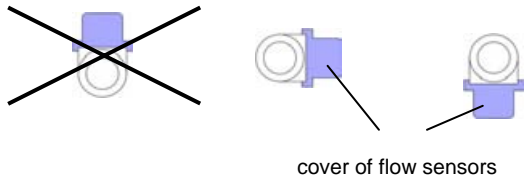

Allowed position of the cold meter

Electronic unit

The ambient temperature of the electronic unit must not exceed 55°C. Direct sunlight must be avoided.

For heating water temperatures between 10°C and 90°C, the electronic unit can remain on the volume measuring unit or be mounted on the wall (split mounting). On the wall or on the volume measuring unit, the adapter plate can be oriented to make it easy to read the display. To remove the electronic unit, push the housing upward and remove. The adapter plate for wall mounting can now be unscrewed or the electronic unit simply rotated and pushed back into the required position until it latches.

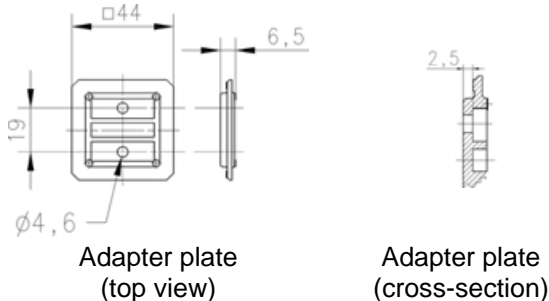

Adapter plate (top view)

Adapter plate (cross-section)

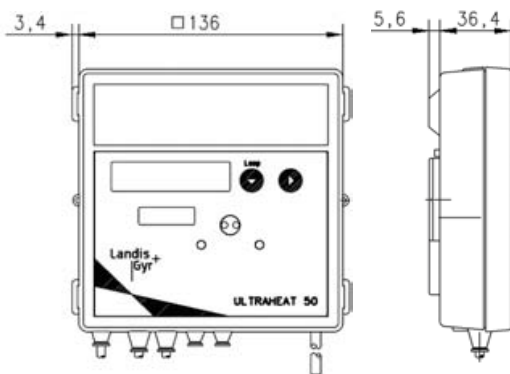

For heating water temperatures between 10°C and 90°C, the electronic unit must be fixed on the wall (split mounting). For this purpose, remove the electronic unit from the adapter plate, unscrew the adapter plate from the volume measuring unit, and screw to the wall with plugs. Push the electronic unit on again.

A heat meter with a **removable control cable** may be separated during the installation. When installation is done be sure that only paired parts (volume part, calculator) are connected together. The control cable must not be extended!

Power supply

The heat meter can be powered either with a battery or via power supply modules. The 110 V / 230 V power supply modules are encapsulated and comply with safety class II. The modules can be retrofitted or upgraded at any time.

In the standard version, a battery is inserted in the factory. This must not be opened. It must not come into contact with water or be exposed to temperatures exceeding 80°C. Used batteries must be disposed of at suitable waste disposal facilities.

In a special version, a power supply module can be installed. In the 110 V AC and 230 V AC versions, a cable is brought out in the factory that must be connected to the line voltage accordingly. The 24 V AC/DC version has terminals instead of a cable.

The 110 V or 230 V power supply unit must be fuse-protected with 6 A near to the heat meter and protected from tampering.

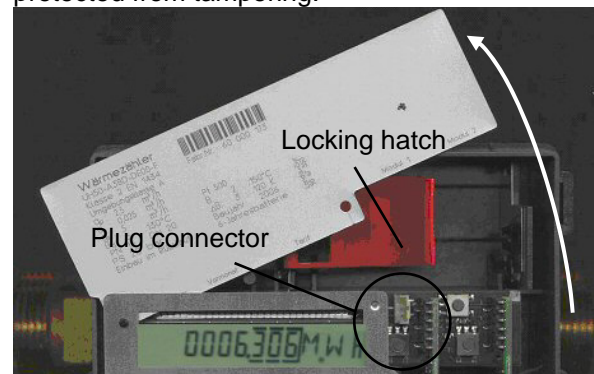

Insert the battery

Press the four side tabs of the housing cover inward and remove the cover. Then turn the label plate counterclockwise until you feel it has gone as far as it will go.

Swing open the red locking hatch to expose the relevant battery compartment (left compartment for 2x "AA" or "C", right compartment for "D").

Insert the battery into the relevant compartment of the electronic unit with the correct polarity as marked.

Turn the label plate back clockwise into its original position.

Note: "AA" and "C" size batteries are snapped into a holder.

In case of a meter's return via airfreight the battery ("C" and "D" cell) has to be generally dismantled and forwarded separately from the meter.

Mounting the power supply module

Instead of the battery, a power supply module (110 V / 230 V with connected cable, 24 V with terminals) can also be installed. This is done by moving the red locking hatch to the left to open the right-hand compartment for the power supply module. Remove the right-hand outside rubber sleeve upward, pull out the plugs and thread the connecting cable (line voltage) of the module through the sleeve. Insert the module in the upper right-hand corner of the electronic unit and re-insert the sleeve with the cable from above. Connect the conductors as labeled. Plug the other connecting cable (low voltage) onto the plug connector on the circuit board.

Note: For the 24 V AC/DC version, cable with a diameter greater than 5.0...6.0 mm should not be used!

☞ **The 110 V / 230 V versions must only be connected by an electrician!**

When replacing a unit after the calibration period has elapsed, swing out the power supply module with the cable and sleeve, mount the new heat meter, and re-insert the module. Because it complies with safety class II, the line power supply does not have to be disconnected.

Interfaces of the electronic unit

The UH50 heat meters are equipped with an optical interface per EN 62056-21:2002 as standard. Moreover, up to two of the following communication modules can be used for remote reading:

- Pulse module (pulses for quantity of heat / volume / unit status / tariff register 1 / tariff register 2; isolated, bounce-free)
- CL module (passive 20 mA current loop per EN 62056-21:2002)
- M-bus module per EN 1434-3, fixed and extended, variable protocol (also for coupling with a suitcase heating controller)
- Analog module
- Radio module
- Multi-module (external)

These modules are have no effect on consumption metering and can therefore also be replaced at any time without violating the adhesive label.

Communication modules

In the lower right-hand area, up to two communication modules can be installed in the factory.

At a later installation the necessary ESD protection measures has to be considered.

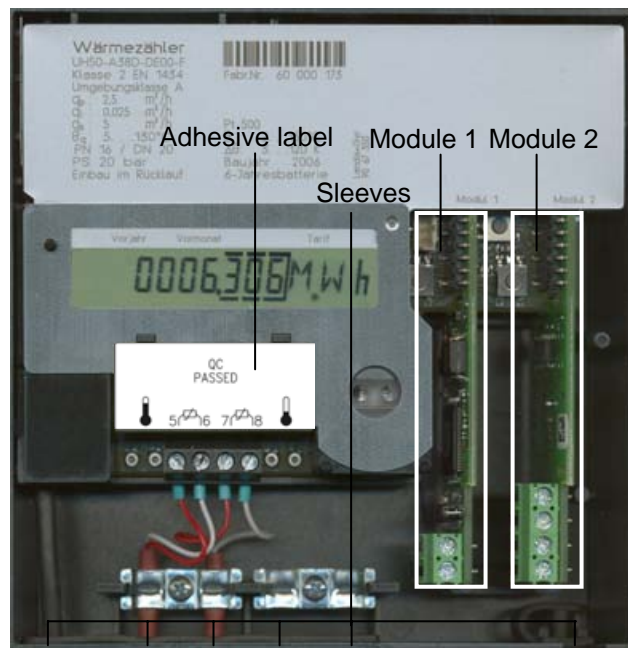

For further technical details and data on the module, see the technical documentation.

Terminals

2-pole and 4-pole terminals are used for connecting external cables to the modules.

Strip-back length 5 mm

Connection capacity

- rigid or flexible, 0.2 - 2.5 mm²
- flexible with end ferrules, 0.25 - 1.5 mm²
- conductor sizes 26 - 14 AWG

Multiple-conductor connection (2 conductors of same cross-section)

- rigid or flexible, 0.2 – 0.75 mm²
- flexible with end ferrules without plastic sleeve, 0.25 – 0.34 mm²
- flexible with TWIN ferrules with plastic sleeve, 0.5 – 0.75 mm²

Recommended screwdriver:

- 0.6 x 3.5 mm

Tightening torque: 0.4 Nm

Permissible combinations of modules

A pulse module with “fast” pulses must always be inserted as module 2. Note: Subsequent mounting of a further pulse module in module slot 1 can result in changed output values for module 2!

The radio module must also always be inserted as module 2.

Further restrictions are shown in the following table.

		Slot for module #2 is equipped with...						
		AM	Pulse module		MB	CL	RM	
			"standard"	"fast" *)				
Slot for module #1 can be equipped with ...	AM	yes	yes	yes	yes (4)	yes	yes	
	Pulse module	"standard"	yes	yes (3)	yes (2)	yes (4)	yes	yes
		"fast"	no	no	no	no	no	no
	MB	yes	yes	yes	yes (4)	yes (1)	yes	yes
	CL	yes	yes	yes	yes (1)	no	yes	yes
	RM	no	no	no	no	no	no	no

AM = Analog module
 MB = M-bus module
 CL = CL module
 RM = Radio module

Sensors installed by the customer

In the case of sensors provided by the customer (max. cable length 5 m – an extension is impermissible!), the 2nd and 3rd sleeve from the left must be cut to ensure the correct cable cross-sections.

Unlatch the housing cover by pressing in the side tabs and remove it. Route the cable of the flow sensor from outside through the 2nd sleeve, the cable of the return sensor through the 3rd sleeve. Strip back both cables as shown in the diagram.

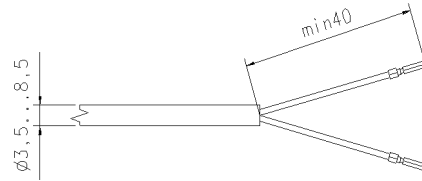

Wire-end ferrules

Connect the conductors as shown on the circuit diagram printed on the unit. The 2-wire connection is made at terminals 5/6 and 7/8. No cable shield must be connected to the heat meter. Then inset the sensors in the pockets, ball valves, or T-elements and seal against tampering.

If an error message "F8" is shown, it can be reset via the parameter setting menu (see following). Replace the housing cover and press it in gently until you hear all the tabs latch.

Parameter setting

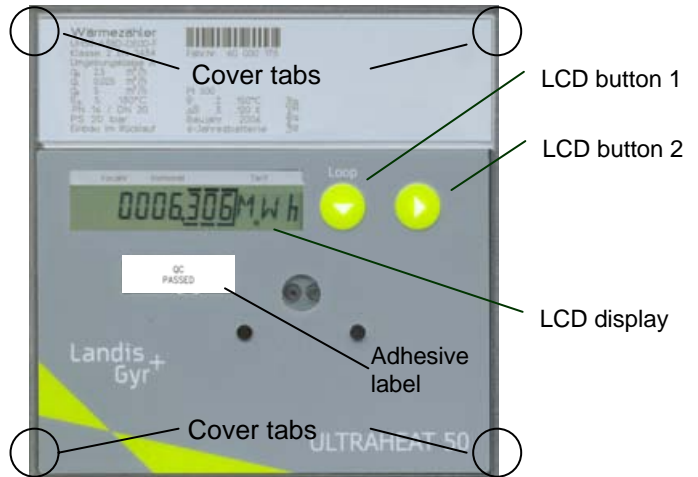

Note: The housing cover has to be removed temporarily in order to operate the service button.



Setting the date / time

Units with a power supply unit or new battery connected in situ may start directly in the setting menu for the date and time.

D 100506	Enter the date
T 105959	Enter the time
Nb-----	Return to normal mode (manual)

Press LCD button 1 repeatedly until the required value is shown. Then press LCD button 2. Change the value for the date or time as described under *Performing parameter setting*.

*) only 1 module with fast pulses is possible, only permissible on slot 2; min. pulse duration = 2 ms, if pulse module 1 not fitted

- (1) For M-bus with controller coupling, the CL read-out can take up to 40 s
- (2) Pulse length of the fast pulses min. 5 ms
- (3) The first and second channel can be parameterized individually
- (4) The secondary address for both modules can only be changed via module No. 1

Installing a communication module

The communication modules are connected via a 6-way reaction-free connector so that installation or replacement is possible at any time.

Put the communication module in the correct position, carefully insert it into the two guide slots, and push it in.

For connection with the external cable, strip the sleeve to ensure the correct cross-section of the connecting cable. Feed the cable through the sleeve from outside, strip it back and connect it. A cable shield must not be connected to the heat meter.

Unsure you use the correct slot for the modules and comply with the permissible combinations.

Factory-installed sensors

Do not disconnect, shorten, or extend the cables of factory-installed sensors.

Calling the parameter setting function

Press the service button for about 3 s. The LCD shows the display **PRUEF----**.

In this state, you can parameterize the tariffs and fast pulses using the PappaWin software.

Caution: For fast pulses in battery operation, a D cell is required.

LCD button 1 advances the display.

PRUEF----	Call test mode
PARA-----	Call parameter setting mode
Nb-----	Return to normal mode (manual)

Press LCD button 1 repeatedly until "PARA" is shown. Then press LCD button 2.

The following parameter settings are possible:

F8	+	Reset error message F8 (only displayed if F8 is pending)
Ma	+	Reset the maxima
Fd	+	Reset the missing time and the flowrate measuring time
SD 3 105--		Enter the yearly set day (day and month) *
SD 3 1--		Enter the monthly set day (day) *
D 100506		Enter the date (day, month, year) *
T 105959		Enter the time (hour, minute, second) *
K 12345678		Enter the property number, 8-digit (also M-bus secondary address)
AP1 0		Enter the M-bus primary address for module 1 (0..255) *
AP2 0		Enter the M-bus primary address for module 2 (0..255) *
Modul 1-1 CE		Select the first module function for module 1 (CE or C2)
Modul 1-1 C2		
Modul 1-2 CV		Select the second module function for module 1 (CV or CT or RI)
Modul 1-2 CT		
Modul 1-2 RI		
Modul 2-1 CE		Select the first module function for module 2 (CE or C2)
Modul 2-1 C2		
Modul 2-2 CV		Select the second module function for module 2 (CV or CT or RI)
Modul 2-2 CT		
Modul 2-2 RI		
MP 60 min		Select the maxima measuring period: 7.5-15-30-60 min / 3-6-12-24 h
Nb-----		Return to normal mode

*) It is up to the user to ensure that only meaningful values are entered. No plausibility check is made and "incorrect" values can be applied (month > 12 etc.)

Note: The functions for modules 1 and 2 are also offered if no or any other module is plugged.

In this way, the heat meter can be parameterized before the modules are fitted.

The required size is selected with the LCD button 1 and activated with the LCD button 2.

Note: Parameter setting can be exited by pressing the service button again ("escape function"). In this case, the last valid value is displayed unchanged.

Performing parameter setting

LCD button 2 is used to change the blinking digit step by step or reset error F8 or the maxima. LCD button 1 applies the value set in the blinking digit. The next digit to the right of this then blinks, can be set again with the LCD button 2 and can be applied with LCD button 1. As the final acknowledgment of a display line, a star symbol is briefly displayed.

If incorrect entries are made, parameter setting be performed again.

Completing parameter setting

Parameter setting mode is exited:

- by pressing LCD button 2, when the display shows **Nb-----**
- Automatically after 15 hours

Start-up

Replace the housing cover and press it in gently until you hear all the tabs latch. Open the shut-off valves. Check the heating system for tightness and vent it carefully.

No more than 100 s later, message F0 will disappear. After that, check that the displays for flowrate and temperatures are plausible. Vent the system until the flowrate display is stable. Adjust the system with the flowrate display (updated in the flowrate timebase).

Seal the sensors. Attach user seals to the electronic unit and the sensors.

Read and note down the meter readings for quantity of heat, volume, operating time, and missing time.

We recommend resetting the maxima and the missing time (see parameter setting).

Error messages on incorrect mounting:

FL nEG	Heat meter was mounted the wrong way round, against the intended direction flow
dIFF nEG	Temperature sensors were swapped round during mounting or connection

Note: During a system stoppage, these messages may appear although mounting was correct.

Displays

The places after the decimal point of displayed values are indicated by a surrounding border.

Calibrated values can be recognized by the star symbol shown in addition to the value.

The displays of the heat meter are arranged on several levels (LOOPS). LCD button 2 advances the display of the user loop (LOOP 0) cyclically.

Note: Depending on how the unit is parameterized, the number of items displayed and the data shown may differ from this description. Certain button functions may also be disabled.

User loop ("LOOP 0")

LOOP 0	Head of the loop
1234567 kWh	Accumulated quantity of heat with tariff status
T' 1234567 kWh	Tariff register 1 (optional)
123456 m ³	Accumulated volume
8888888 kWh	Segment test
F -----	Error message with error code number

LCD button 1 is used to switch the display from the user loop to the selection of service loops (LOOP 1..n).

Service loops (selection)

LOOP 1	Service loop 1
LOOP 2	Service loop 2
...	...
LOOP n	Service loop n

LCD button 1 advances the display to the next loop. After the last loop, the user loop (LOOP 0) appears again.

LCD button 2 displays the content of the selected service loop.

Within a loop, the LCD button 2 is used to advance to the next line of the display. After the last line of the display, the first display line appears again.

Service loop 1 ("LOOP 1")

LOOP 1	Head of the loop
1234 m/h	Current flowrate
904 kW	Current heat power
91 56 °C	Current flow/return temperature
3d 1234 h	Operating time
Pd 1234 h	Operating time with flowrate
Fd 123 h	Missing time
K 12345678	Property number, 8-digit
D 100506	Date
SD 3105--	Yearly set day (DD.MM)
1234567 kWh	Quantity of heat previous year on set day
1234567 m³	Volume for previous year on set day
FW1 5-00	Firmware version

Service loop 2 ("LOOP 2")

In service loop 2, the **maxima** are displayed. LCD button 2 calls the displays one after the other.

LOOP 2	Head of the loop
Ma 3899 m/h	Max. flowrate, at 2s intervals with date stamp
St 13,1205	
Ma 2889 kW	Max. power, at 2s intervals with date stamp
St 11,1205	
Ma 98 87 °C	Max. temperatures, at 2s intervals with date stamp
St 08,1205	for flow and return maximum
St 04,1205	
MP 60 min	Measuring period for maximum calculation

Service loop 3 ("LOOP 3")

Service loop 3 shows the **monthly values**. LCD button 1 is used to select a month out of the 18 previous months. The data for that month are then opened with LCD button 2. Each further press of LCD button 2 shows the next value for the selected month.

LOOP 3	Head of the loop
010106 M	Set day for December 2005
011205 M	Set day for November 2005
...	...
010804 M	Set day for July 2004

using LCD button 2: ↓

1234567 kWh	Quantity of heat on the set day
T' 1234567 kWh	Tariff register 1 on the set day
1234567 m³	Volume on the set day
Ma 3899 m/h	Max. flowrate on the set day, at 2s intervals with date stamp
St 13,1205	
Ma 2889 kW	Max. heat power on the set day, at 2s intervals with date stamp
St 11,1205	
Ma 98 87 °C	Max. temperatures on the set day, at 2s intervals with date stamp
St 08,1205	for flow and return maximum
St 04,1205	
Fd 123 h	Missing time count on the set day

After the last display, the previously selected set day is displayed again. Pressing LCD button 1 selects the next set day.

Note: If you want to drop out and go directly to the next loop, choose a monthly value by pressing LCD button 2 and then press LCD button 1.

Service loop 4 ("LOOP 4")

Service loop 4 shows the **unit parameters**. LCD button 2 calls the displays one after the other.

LOOP 4	Head of the loop
T2 0000 m/h	Current tariff, at 2s intervals with threshold value 1
' 0000 m/h	
FP 200 SEC	Measuring interval for flowrate
TP 30 SEC	Measuring interval for temperature
Modul 1 M3	Module 1: M-bus module
AP1 127	M-bus primary address 1
A 12345678	M-bus secondary address 8-digit
Modul 2-1 CE	Module 2: pulse module; chan. 1 = heat quantity
Modul 2-2 CV	Channel 2 = volume, at 2s intervals
PO1 125,00 kWh/l	Significance for heat quantity pulses *)
PO2 00250 L/l	Significance for volume pulses *)
PO3 2ms	Pulse duration in ms *)

*) for "fast pulses"

Previous year's values

The electronic unit stores the current meter readings for quantity of heat, volume, the tariff register, missing time, and flowrate measuring time as well as the service life maxima for flowrate, power, temperature difference, flow temperature, and return temperature with their date stamps on a yearly set day.

Monthly values

The electronic unit stores the meter readings for quantity of heat, volume, the tariff register, missing time, and flowrate measuring time as well as the monthly maxima for flowrate, power, temperature difference, flow temperature and return temperature with their date stamp for 18 months on the set day of each month.

Note: The standard time used is Central European Time (CET). If daylight-saving time is activated, storage will be performed accordingly.

The monthly values can also be read out via the optical and the 20 mA interface.

Error messages

The heat meter constantly performs self-diagnostics and can display various error messages.

Error code: Error / action to be taken:

F0	No flow; Air in measuring unit / pipe, vent pipe
F1	Interruption of flow sensor
F2	Interruption of return sensor
F3	Electronic for temperature evaluation defective
F4	Battery empty; replace!
F5	Short-circuit flow sensor
F6	Short-circuit return sensor
F7	Fault in the internal memory
F8	F1, F2, F3, F5 or F6 pending for longer than 8 hours. No more measurements are performed.
F9	Error in the electronics

Message F8 has to be reset in parameter setting mode (manually, PappaWin). All other error messages are cleared automatically once the error has been corrected.

Functional details

If the response thresholds are exceeded and the flowrate and temperature difference are positive, the **quantity of thermal energy** and the **volume** are summated. In the **segment test**, all segments of the display are switched on for test purposes.

On the **yearly set day**, the meter readings for quantity of heat and volume, the values for the service life maxima and the flowrate and missing times are placed in the **previous year memory**.

The **flowrate**, **heat power**, and **temperature difference** are acquired with the correct sign. If the response threshold is not reached, the value is preceded by a **u**. The current **temperatures** are shown together on one line of the display as integers in **°C**.

To calculate the maximum, the heat power and flowrate are averaged over a **measuring period** of, for example, 60 min. The **maximum values** from the average calculation are preceded by **Ma** on the LC display.

The 8-digit **property number** (also the secondary address in M-bus operation), can be set in parameter setting mode. The **unit number** is assigned by the manufacturer.

The **operating time** is counted from the first time the power supply is connected. **Missing times** are summated, if an error is pending that prevents the heat meter from measuring. The **date** is incremented daily.

The type of installed **modules** is displayed. If an M-but module is installed, the primary and secondary address will be displayed on the following lines.

The number for the **firmware version** is assigned by the manufacturer.

Notes

- Regulations on the use of heat meters must be observed, see EN 1434, Part 6!
In particular, cavitation in the system must be avoided.
- Heat meters up to DN25 may only be installed with directly immersed sensors according to German calibration law!
- Install the unit in such a way that no water can enter the electronic unit during operation.
- All information given on the data sheet of the heat meter must be observed.
- User seals may only be removed by authorized persons for service purposes and must be replaced afterwards.
- No later than 30 seconds after installation, the heat meter detects the plugged modules automatically and is ready for communication or pulse output.
- The type of modules plugged can be displayed in the service loop depending on how the display is parameterized.
- For fast pulses, the parameters must be set accordingly with the PappaWin software.
- Up-to-date versions of all instructions can be found in the Internet at www.landisgyr.com

Landis+Gyr GmbH
Humboldtstr. 64
D-90459 Nuremberg
Germany